



TEMPERATURE CONTROL
FOR TODAY & TOMORROW

mitsubishi
HEAVY INDUSTRIES

FDTC100VNXWPVH

Capacitate nominala de racire: **10.0 KW**



Poze unitate interna si unitate externa



Specificatii

Unitate internă		FDTC50VH x 2	
Unitate externă		FDC100VNX-W	
Sursă de alimentare		Monofazic 220-240V, 50Hz / 220V, 60Hz	
Capacitate nominală de răcire (Min-Max)		kW	10.0 (3.5 ~ 11.2)
Capacitate nominală de încălzire (Min-Max)		kW	11.2 (2.7 ~ 12.5)
Power Consumption	Răcire/Încălzire	kW	2.60 / 3.04
EER/COP	Răcire/Încălzire	kW	3.84 / 3.69



TEMPERATURE CONTROL FOR TODAY & TOMORROW



Curent de intrare			A	5
Max. current			A	25
Nivel putere sonoră*1	U.I.*3	Răcire/Încălzire	dB(A)	59 / 59
	U.E.	Răcire/Încălzire		67 / 67
Nivel presiune sonoră*1	U.I.*3	Răcire (P-Hi/Hi/Me/Lo)		44 / 40 / 35 / 27
		Încălzire (P-Hi/Hi/Me/Lo)		44 / 40 / 35 / 27
	U.E.	Răcire/Încălzire		53 / 51
Flux de aer	U.I.*3	Răcire (P-Hi/Hi/Me/Lo)	m ³ /min	13 / 11 / 9 / 7
		Încălzire (P-Hi/Hi/Me/Lo)		13 / 11 / 9 / 7
	U.E.	Răcire/Încălzire		100 / 100
Exterior dimensions	U.I.	HeightxWidthxDepth	mm	Unitate: 248 x 570 x 570 Panou: 10 x 620 x 620
Greutate netă	U.E.	U.I./U.E.	mm	1,300 x 970 x 370 16.5(Unitate:14 Panou standard:2.5) / 97
			kg	
Refrigerant charge			kg/TCO ₂ Eq	4.0/2.7
Refrigerant Type GWP				R32/675
Ref.piping size	Lichid/Gaz		Ă,mm	9.52(3/8") / 15.88(5/8")
Lungime țeavă refrigerant (o direcție)			m	Max. 100
Diferență de nivel suportată	Unitate externă este mai sus/mai jos		m	Max.50 / Max.15

Datorită politicii de continuă îmbunătățire a produselor, ne rezervăm dreptul de a modifica specificațiile tehnice fără nicio notificare prealabilă.



TEMPERATURE CONTROL FOR TODAY & TOMORROW



Interval de funcționare - temperatură exterioară	Răcire*2	°C	-15~50
	Încălzire	°C	-20~20
Panou			TC-PSA-5AW-E, TC-PSAE-5AW-E(Fagure) / TC-PSAG-5AW-E, TC-PSAGE-5AW-E(Grid)
Filtru de aer, cantitate			Filtru lavabil din plastic x 1 (Lavabil)
Telecomandă (opțional)			Cu fir:RC-EX3A, RC-E5, RCH-E3, Wireless:RCN-TC-5AW-E2, -E3
Clasa Energetică (Răcire/Încălzire)			A++/A+
SEER			6.58
SCOP (Climat temperat)			4.16
Pdesign (răcire/încălzire(@-10°C))			10.0/11.2
Annual Electricity Consumption			532/3772
Performanța pe modul încălzire			Climat temperat

Schema tehnica

Datorită politicii de continuă îmbunătățire a produselor, ne rezervăm dreptul de a modifica specificațiile tehnice fără nicio notificare prealabilă.



TEMPERATURE CONTROL FOR TODAY & TOMORROW



FDC100VN-X, 125VN-X, 140VN-X, 100VS-X, 125VS-X, 140VS-X

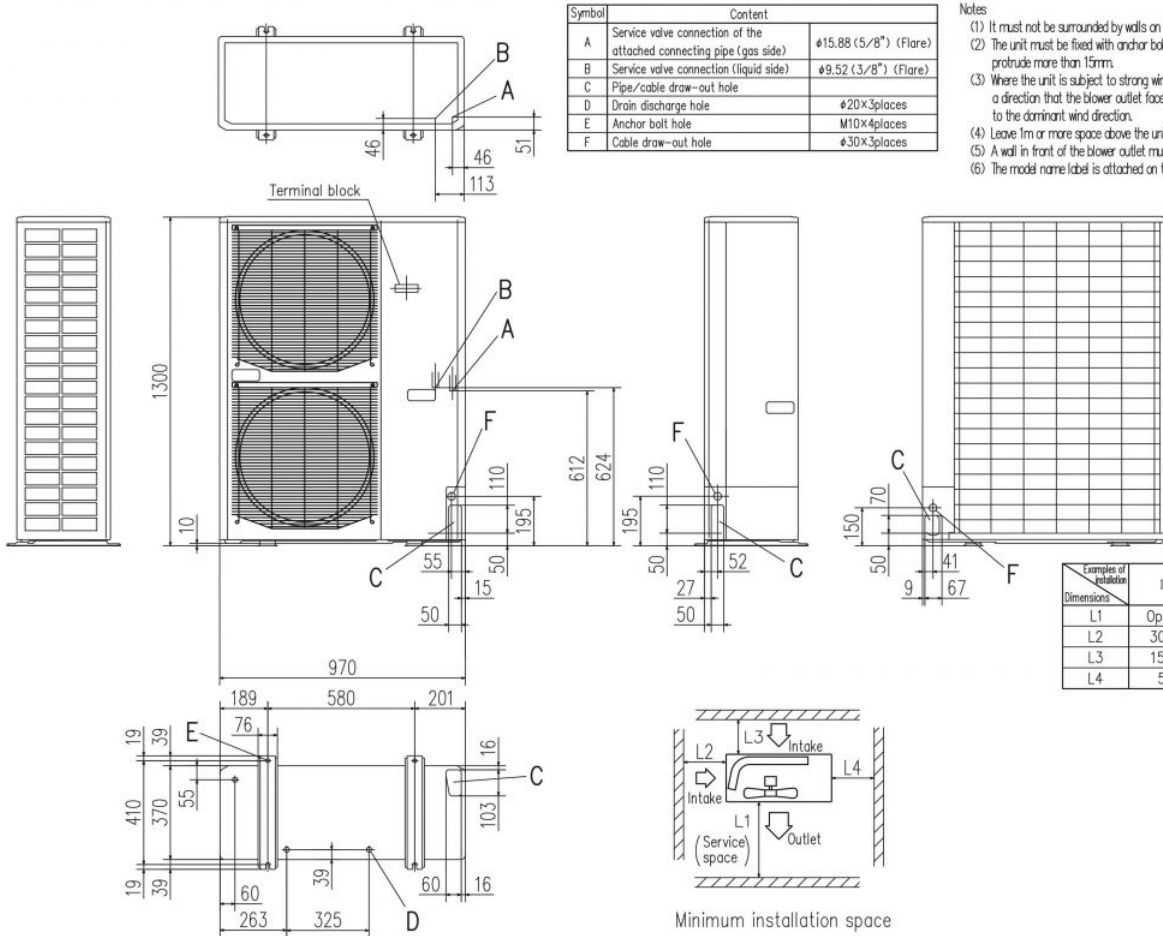

Symbol	Content	
A	Service valve connection of the attached connecting pipe (gas side)	φ15.88 (5/8") (Flare)
B	Service valve connection (liquid side)	φ9.52 (3/8") (Flare)
C	Pipe/cable draw-out hole	
D	Drain discharge hole	φ20×3places
E	Anchor bolt hole	M10×4places
F	Cable draw-out hole	φ30×3places

- Notes
- (1) It must not be surrounded by walls on the four sides.
 - (2) The unit must be fixed with anchor bolts. An anchor bolt must not protrude more than 15mm.
 - (3) Where the unit is subject to strong winds, lay it in such a direction that the blower outlet faces perpendicularly to the dominant wind direction.
 - (4) Leave 1m or more space above the unit.
 - (5) A wall in front of the blower outlet must not exceed the units height.
 - (6) The model name label is attached on the lower right corner of the front panel.

Example of installation Dimensions	I	II	III
L1	Open	Open	500
L2	300	5	Open
L3	150	300	150
L4	5	5	5

FDTC25VH1 FDTC35VH1 FDTC40VH FDTC50VH FDTC60VH

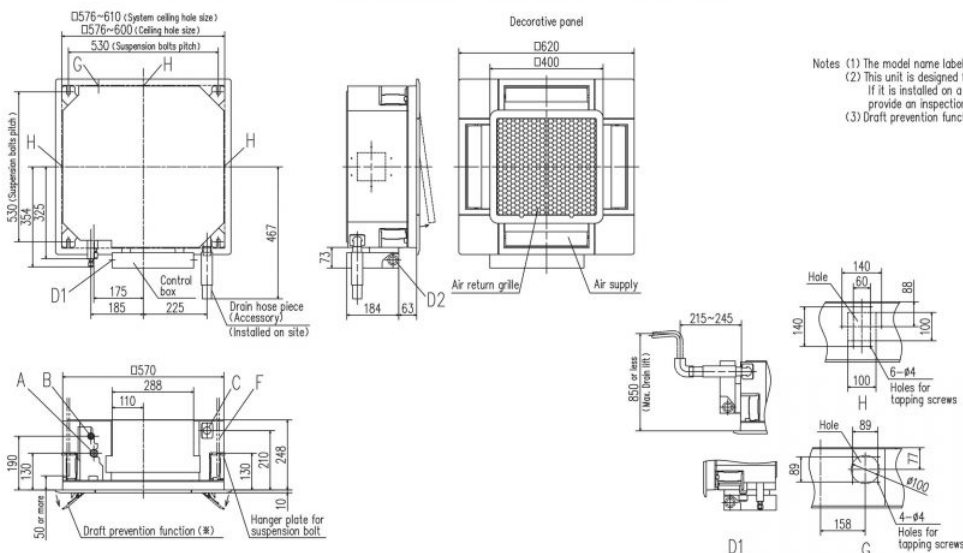

- Notes
- (1) The model name label is attached to the control box lid.
 - (2) This unit is designed for 2x2 grid ceiling. If it is installed on a ceiling other than 2x2 grid ceiling, provide an inspection opening on the control box side.
 - (3) Draft prevention function (#) is provided on the panel TC-PSAE-SAW-E only.

Symbol	Content	
A	Gas piping	25-35 φ9.52/3/8" (Flare) 40-60 φ12.7/1/2" (Flare)
B	Liquid piping	φ6.35 (1/4") (Flare)
C	Drain piping	VP25 (O.D.32)
D1	Power supply connection	
D2	Remote control code and signal wiring connection	
F	Suspension bolts	M10 or M8
G	Outside air opening for ducting	(Knock out)
H	Air outlet opening for ducting	φ125 (Knock out)
J	Inspection opening	450X450

Datorită politicii de continuă îmbunătățire a produselor, ne rezervăm dreptul de a modifica specificațiile tehnice fără nicio notificare prealabilă.